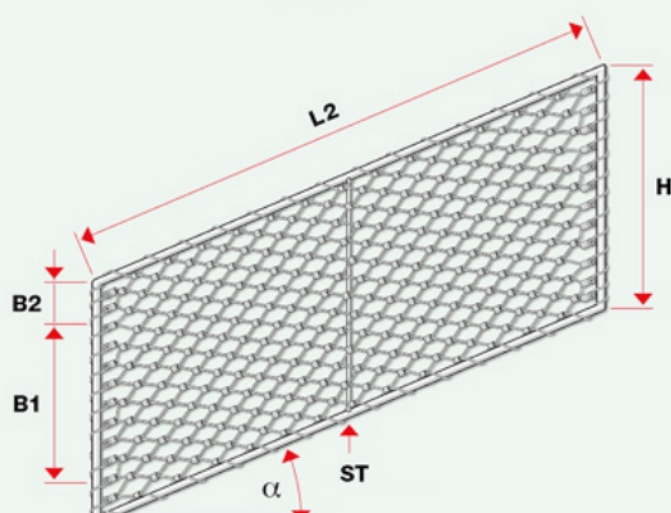
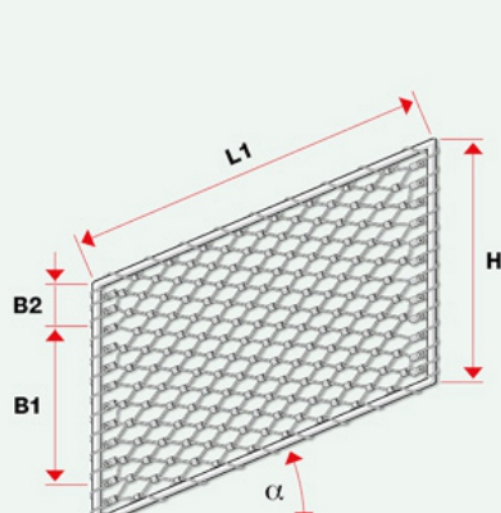
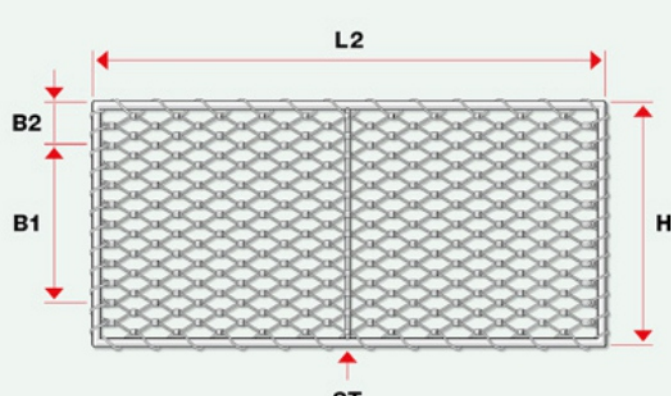
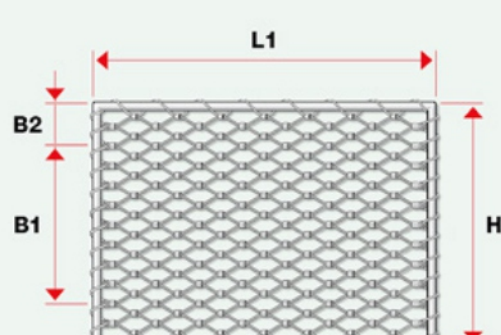

TECHNICAL PARAMETERS - TUBULAR FRAME (OUTER BRAIDING)

Ø mm	17.2 x 1.6	26.9 x 2.0	33.7 x 2.0	42.4 x 2.0
max. H mm	1000	1000	1000	1000
max L1 mm	800	1200	1400	1600
max L2 mm	1600	2400	2800	3200
ST Ø mm	10	12	17.20	17.20

Rope net wire diameter: Ø 1.0 – 3.0 mm

TECHNICAL PARAMETERS – TUBULAR FRAME (MILLED)

Ø mm		26.9 x 2.0		
max. H mm		1000		
max L1 mm		1200		
max L2 mm		2400		
ST Ø mm		12		

Rope net wire diameter: Ø 1.0 – 2.0 mm

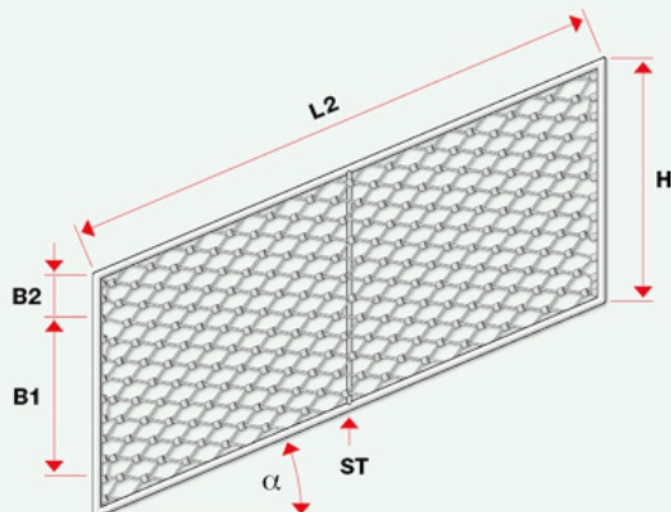
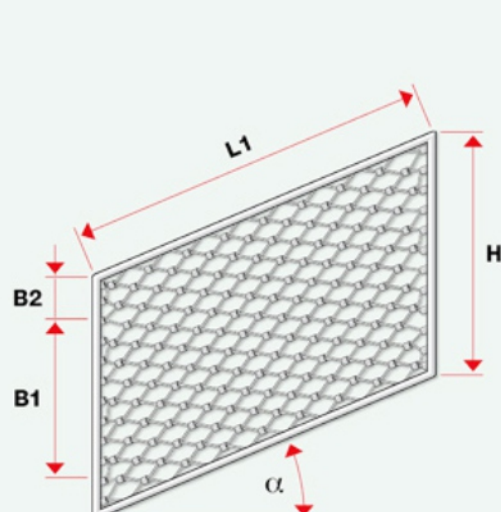
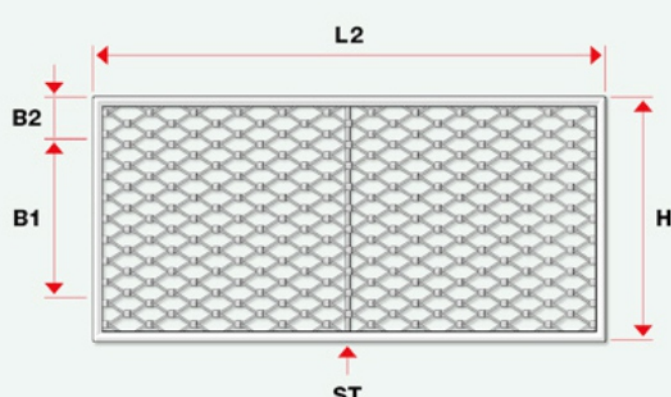
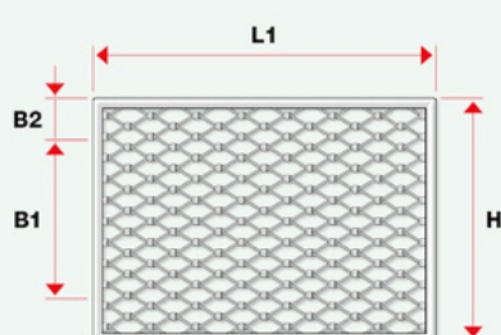
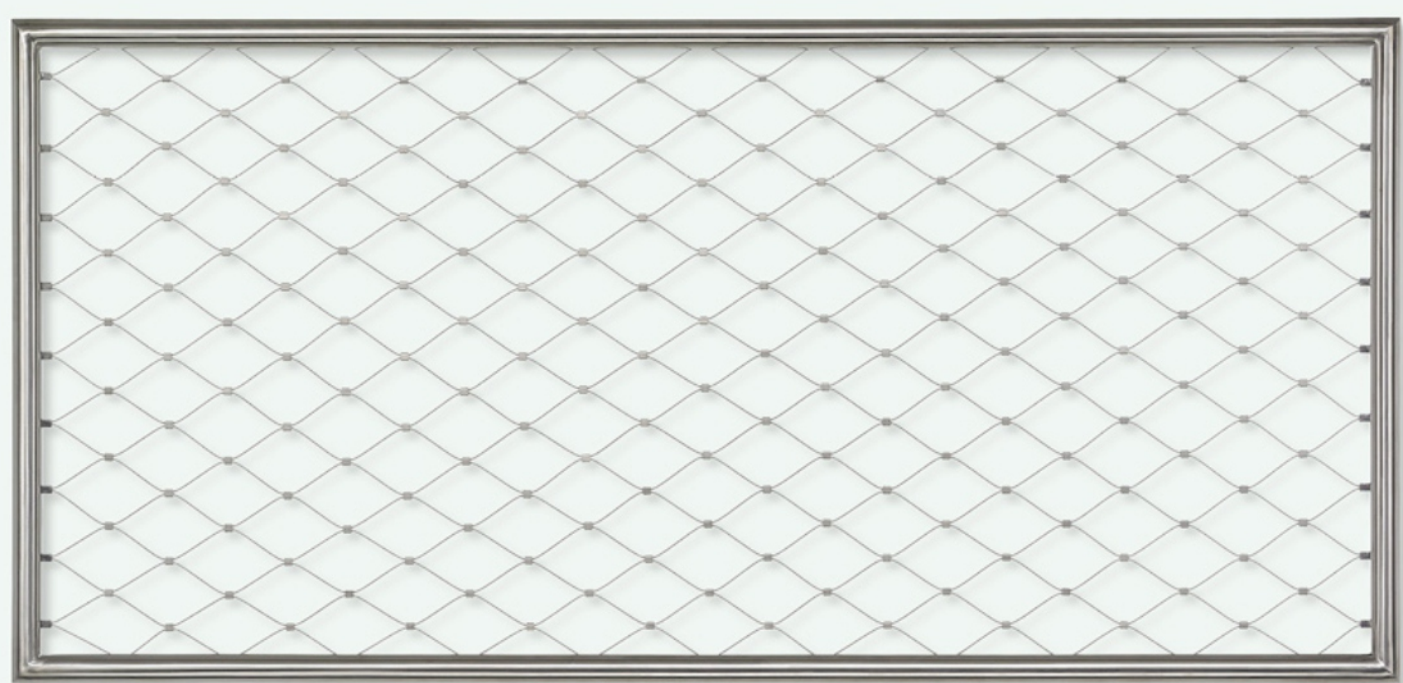
TECHNICAL PARAMETERS – PROFILE FRAME (MILLED)

Ø mm	20 x 20 x 1.50	20 x 40 x 1.50	25 x 50 x 1.50	30 x 30 x 1.50	30 x 60 x 1.50	40 x 40 x 2.00
max. H mm	1000	1000	1000	1000	1000	1000
max L1 mm	800	1200	1400	1200	1600	1200
max L2 mm	1600	2400	2800	2400	3200	2400
ST Ø mm	12	12	12	12	12	12

Rope net wire diameter: Ø 1.5 – 2.0 mm

